

Automatic Power Factor Compensation for Industrial Use to Minimize Penalty

Dharmesh J. Pandya

Department of Electrical Engineering,
Atmiya University
Rajkot, India
djPandya@gmail.com

Dinesh Kumar Vairavel

Dept of Agricultural Engineering,
Kalasalingam Academy of Research
and Education (KARE)
Krishnankoil, India
autodinesh@gmail.com

Ajay Rana

Amity University
Greater Noida
Uttar Pradesh, India
ajay_rana@amity.edu

Yogendra Kumar

Department of Electrical Engineering
GLA University
Mathura, India
kumar.yogendra@gla.ac.in

A. Deepak

Saveetha School of Engineering,
Saveetha Institute of Medical and
Technical Sciences
Chennai, India
deepakarun@saveetha.com

Durgeshwar Pratap Singh

Department of Mechanical Engineering
Graphic Era Deemed to be University
Dehradun, India
durgeshwar.me@geu.ac.in

A Kakoli Rao

Lloyd Institute of Engineering
and Technology
Greater Noida, India
hodcse@liet.in

Abstract— Power generation efficiency is critical now, as power waste is a global issue. Power factor is a measurement of a system's power efficiency and a key factor in increasing supply quality. A weak power factor caused by the increased use of inductive loads is generally disregarded in most power systems. A power factor correction unit would allow the system to restore its power factor to near unity, which would allow for more cost-effective operation. Reduced power system losses, increased load carrying capacity, enhanced voltages, and more are all benefits of power factor correction. The goal of this project is to create an Automatic Power Factor Correction (APFC) Unit that can monitor a system's energy usage and automatically optimize its power factor.

Keywords—Power factor, Capacitor, Compensation, Industrial, Automatic power factor correction, Tariff.

I. INTRODUCTION

Electricity demand was increased by almost 50% between 2019 to 2030 in India. And due to widely used, it has become a very expensive resource. Electricity prices are usually highest for residential and commercial consumers because it costs more to distribute electricity to them. Plus, the demand of commercial and industrial customers varies greatly throughout the day and for them maximum demand plays an important role in their overall electricity bills. As per the existing tariffs, the power factor is 0.9 or above. That means to avoid the power factor penalty consumer must maintain power factor 0.9 or above. Also, maximum demand plays an important role in their substantial saving and this is the main objective of this project.

II. POWER FACTOR CORRECTION CAPACITORS TYPES

A. Capacitor Rating

A capacitor unit rating is defined by rated voltage and kVAr capacity for example 100 kVAr 440 V. The kVAr

tolerance is -5% to +10%. For example, a 100 kVAr unit output could be anywhere from 95 to 110 kVAr.

$$Q = \frac{kV^2}{X_c} = \frac{\sqrt{3}kVAr}{1000} \quad (1)$$

Where:

-Q is capacitor unit MVar capacity
-kV voltage across capacitor in kV

-Xc is the capacitive reactance per phase in ohms = $1/2\pi fC$
(C is capacitance of the capacitor unit)

-I is the current in amps

The capacitive reactance, Xc is fixed and hence for a given capacitance the kVAr generated is directly proportional to the square of applied voltage.

B. Low Voltage Capacitors

These are three phase units with three bushings or terminals. One terminal for each phase.

As mentioned before these are connected inside the enclosure in delta connection as shown in fig 1. These are IP42 construction and hence can be installed indoor only.

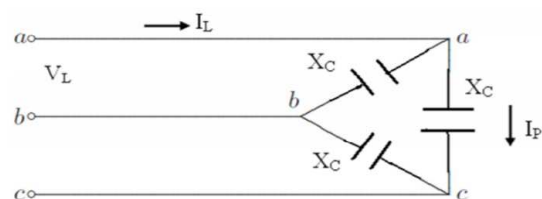

Figure 1. Three-phase delta-connected capacitor bank.

The standard voltages are: 380, 400, 415, 440, 480, 525, 600, 660 and 690 V. The standard kVAr ratings are 2.5, 5, 7.5, 10, 15, 30, 50, 75, 100 kVAr (maximum). The required power factor correction unit capacity is achieved by connecting number of units in parallel. For example, if 200 kVAr capacity is required then either connect two units of 100 kVAr or four units of 50 kVAr in parallel.

C. High Voltage Capacitors

These are available in single and three phase units. These are available in IP42 (to be located indoor only) or IP 55 (can be installed indoor or outdoor) construction. Most manufacturers offer IP55 construction only. The three phase units are available either star or delta connected internally. Every manufacturer will not offer delta and star connected units. Some may offer only one of them while others may offer both (star and delta connected units) [4].

The standard three phase and single-phase unit rated voltages are: 3.3, 6.6, 11, 17.5 or 24 kV. The standard unit ratings are 50 to 1000 kVAr. But the voltage and kVAr range is different for each manufacturer and also the entire kVAr range may not be available in all rated voltages [5].

1. **Single Phase Units:** The single phase units are generally used by power utilities for voltage improvement. These units have either one live plus one dead or two live bushings.

The one live and one dead bushing units are used in star grounded formation. The two live bushings units are used in star ungrounded formation.

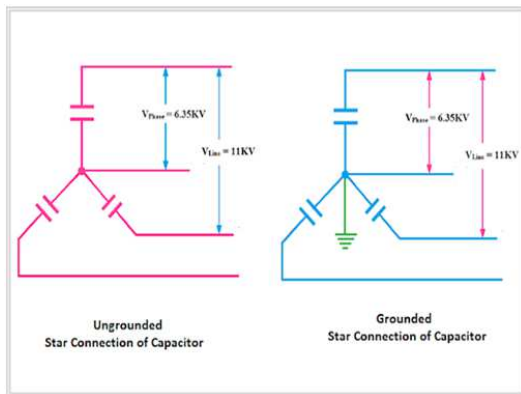

Figure 2. Single phase Under grounded and Grounded star connected of Capacitor.

2. **Three phase units:** Three phase units are internally connected in either star (ungrounded) or delta. Three phase delta connected units are used for power factor improvement applications in a consumer’s system because for the same capacitance the kVAr output is more than star ungrounded units.

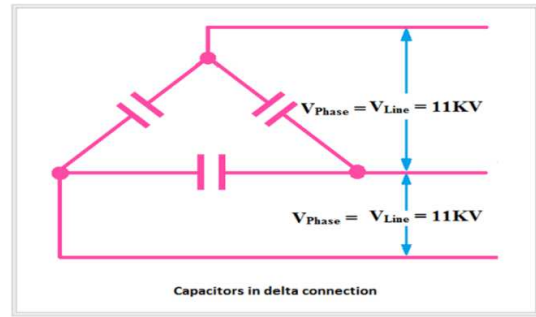

Figure 3. Three-phase Capacitor in delta connection

a. Capacitor Characteristics

- **Overcurrent:** Capacitors are rated for 1.3 times the rated continuous current. This is a requirement of international standards. This is to account for higher than the rated current due to various reasons such as harmonic currents, tolerance on capacitance etc.

For example, a 100 kVAr, 440 V capacitor unit:

$$Q = \frac{\sqrt{3} \times kV \times I}{1000} \quad (2)$$

$$I = \frac{Q \times 1000}{\sqrt{3} \times kV} = 132 \text{ amps} \quad (3)$$

Where:

-Q is capacitor unit MVar capacity

-kV voltage across capacitor in kV

-I is the current in amps

This unit will be designed to continuously withstand 1.3 x 132 = 172 A current.

- **Over voltage:** Capacitors must not be subjected to higher than rated voltage. If there is a possibility of overvoltage occurring due to a fault then sensing it and means to automatically disconnect the bank must be provided. If Un is the capacitor unit rated voltage.

TABLE I. CAPACITOR VOLTAGE AND DURATION

Voltage	Maximum Duration
1.0 Un	Continuous
1.1 Un	12 hrs in every 24 hrs
1.15 Un	30 min every 24 hrs
1.2 Un	5 min
1.3 Un	1 min

3. **Temperature Category:** Capacitors are extremely sensitive to ambient temperature i.e. for indoor units the temperature of the room they are installed in and for outdoor units the outdoor temperature [6]. They fail if this temperature goes outside the

rated temperature of the unit. Capacitor units are available in four temperature withstand categories:

- A 40 degree C, maximum
- B 45 degree C, maximum
- C 50 degree C, maximum
- D 55 degree C, maximum

These are maximum permissible temperatures corresponding to each category.

The minimum permissible temperatures are: -5, -25, -40 and -50 degree Celsius.

4. *Discharge*: When disconnected from the power supply, capacitors retain the charge which must be discharged before working on the capacitor to avoid shock to the operator. Therefore discharge resistances are provided at the terminals of each unit. The resistances are to discharge the unit to 75 V (as per IEC) and 50 V (as per Indian standards):

i. *Inrush Current*: When switched on, the capacitor acts like a short circuit and draws a large transient current (up to 100 times its rated current) generally for up to 4 cycles which reduces slowly to its steady state current.

This inrush current is drawn from two sources:

- The electrical system it is connected to
- Other live capacitors in parallel

Therefore, a series reactor is provided in series with each unit to reduce the inrush current. Generally, a 4% series reactance that of the capacitive reactance of the unit is enough. But the harmonics criteria require a minimum 7% reactance and therefore a 7% reactance is provided [7].

ii. *Resonance and Harmonics*: Capacitors do not produce harmonics. The capacitive reactance $X_c = 1/2\pi fC$, Where C is the capacitance. Higher the harmonics i.e. frequency lower the capacitive reactance.

The system inductive reactance $X_l = 2\pi fL$, Where L is inductance. Higher the harmonics i.e., frequency higher the inductive reactance of the system to which the capacitors are connected [8].

At one of the harmonic frequency the capacitive reactance may become equal to or close to the system inductive reactance. The net reactance $(X_l - X_c)$ will then be zero or low and the capacitors will draw large current $(I = V / (X_l - X_c))$ damaging it.

Therefore, a series reactor is provided in series with each unit (three phase or single phase) to increase the net system reactance and avoid this possibility. That means if a

bank has five units, then five three phase reactors as shown in photo above are provided [9].



Figure 4. Three phase series reactors

III. TYPE OF LOADS AND POWER FACTOR

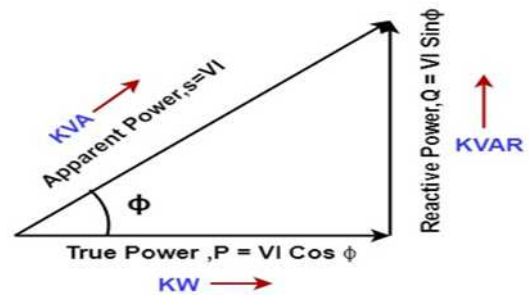

Figure 5. Power Triangle

A. Power factor of different types of loads

TABLE II. POWER FACTOR AND DIFFERENT TYPES OF LOADS

Type of Load	Power Factor
IT servers, computer equipment	0.9 lag to 0.95 lead
Fluorescent tube lights (power factor corrected)	0.85 to 0.95 lag
Compact fluorescent lamps	0.6 lag (but now a days LED lamps used instead of these)
LED Lamps	0.9 lag or better
Resistive loads such as heaters	1
Uninterrupted Power Supply (UPS) Input side	0.9 lag or better
Variable Speed Drive (VSD) input side	0.9 lag or better
Low voltage induction motors	0.7 to 0.94 lag
High voltage induction motors	0.85 to 0.94 lag
Arc Furnace	0.5 to 0.7 lag

IV. NEED FOR THE CONSUMER TO IMPROVE POWER FACTOR

If the power company's consumer tariffs provide an incentive to maintain a decent power factor or impose a penalty if a specific minimum power factor is not met, it is advisable for the consumer to enhance the power factor of the consumer system in order to lower the electricity cost.

V. CALCULATION OF AMOUNT OF KVAR COMPENSATION REQUIRED TO IMPROVE THE POWER FACTOR

A. Total kVar Amount

For a new installation being designed the theoretical and scientific way is to calculate the load kW and kVA. But in real life it is not possible to get power factor of all loads and hence such a scientific calculation is almost impossible

to do. For low voltage power factor correction system at the low voltage main switchboard connected to a transformer the rule of thumb is 40% of the transformer kVA. For example, for a 1000 kVA transformer 400 kVAr (40% of 1000) power factor correction system is adequate and safe to provide.

For existing installation measure the kW and kVA using a meter at the supply point to the consumer. Then using these values calculate average power factor which is equal to kW/kVA [10]. Using average power factor calculate the kVAr capacity required for the power factor correction capacitor bank.

B. Example: MUNICIPAL COUNCIL VAIJAPUR

The electricity bill of 12 October 2021 shows following:

Contract demand = 276 kVA

Maximum kVA demand = 144 kVA

kWh consumed = 4687.250

kVAh consumed = 5988.650

Average power factor = kWh consumed/kVAh consumed = $4687.25/5988.65 = 0.932$

If this power factor is to be corrected to 0.97 then power factor correction amount required =

Option 1: Based on contract demand:

$Q_c = KVA-1 \times \cos\theta_1 \times (\tan\theta_1 - \tan\theta_2) = 276 \times 0.932 \times (0.388 - 0.25) = 35 \text{ kVAr}$

Based on registered maximum demand of the month:

$Q_c = KVA-1 \times \cos\theta_1 \times (\tan\theta_1 - \tan\theta_2) = 144 \times 0.932 \times (0.388 - 0.25) = 18.5 \text{ kVAr}$

Safer to provide 35 kVAr power factor correction unit.

VI. IMPACT OF POWER FACTOR ON DIFFERENT TYPES OF CONSUMERS BASED ON EXISTING TARIFFS

If the consumer power factor is 0.9 or higher, there is no penalty under the current tariffs for consumers to whom the power factor is applicable. That means a consumer must maintain a power factor of 0.9 or higher to avoid the power factor penalty. Only if the power factor is 0.96 or higher does the consumer receive an incentive. To avoid a penalty while also receiving an incentive, a consumer must maintain a power factor of 0.96 or higher [13].

To avoid the penalty, a consumer with a power factor of less than 0.9 would want to improve their power factor. A consumer with a power factor of 0.9 to 0.95, on the other hand, will not pay a penalty but will not receive an incentive [14].

As a result, consumers have two alternatives for increasing their power factor:

Option 1: To avoid the penalty, increase the power factor to between 0.9 and 0.95.

Option 2: Increase the power factor above 0.96 to avoid the penalty and receive a reward.

A. New Tariffs:

MSEDCL wants to move towards kVAh billing instead of existing kWh billing (i.e., tariffs) for all consumers. This is to simplify the billing system by avoiding the need to calculate power factor and also avoid dispute with consumer about power factor.

The kVA demand charge component in the electricity bill will remain same with new tariffs for the applicable consumers [15]. In new tariffs the charges will be based on kVAh instead of kWh recorded by the meter and no penalty or incentive for the power factor.

New consumers (LT and HT) will automatically get new meters. Depending up on the tariff the new meter will record total kVAh only or monthly maximum kVA demand and total kVAh consumed during the billing period [16].

B. Impact on Consumers of New Tariffs:

If the power factor is enhanced, all existing and new customers will save money on their electricity bills. In most cases, new customers install an automatic power factor correction device. Existing customers who haven't already done so can save money by installing an automatic power factor correction device [17].

The impact of these new tariffs on various sorts of customers has been studied in the following sections. Before improvement, a 0.8 lagging power factor was assumed for all consumers. After improvement, the power factor is expected to be 0.95. In practice, the power factor before improvement will vary by consumer type, but will be in the 0.8 to 0.9 lagging range [18].

VII. HOW TO IMPROVE POWER FACTOR

The power factor of a consumer's electrical system can be enhanced by installing an automated power factor correction unit (APFCU) [19].

The Automatic power factor correction unit (APFCU) consists of capacitors which generates leading reactive power (Q_c) which cancels some of the load's lagging reactive power (Y_1) there by improving the load (i.e., system) power factor. The resultant lagging reactive power (Y_2) is smaller than Y_1 and hence power factor becomes better than before.

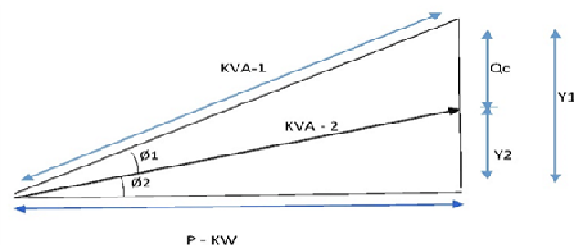

Figure 6. Power factor calculation.

Given KVA-1 demand and power factor before improvement:

$P - KW = \text{Real power} = KVA-1 \times \cos\theta_1$

$Y1$, reactive power before power factor improvement = $\tan\theta_1 \times P$

$Y2$, reactive power after power factor improvement = $\tan\theta_2 \times P$

Compensation required = $Q_c = Y1 - Y2 = P (\tan\theta_1 - \tan\theta_2)$
 = $KVA - I \times \cos\theta_1 \times (\tan\theta_1 - \tan\theta_2)$

Given KW demand i.e., P and power factor before improvement:

Compensation required = $Q_c = Y1 - Y2 = P (\tan\theta_1 - \tan\theta_2)$

The power factor correction system is simple to implement in a new installation by including it in the electrical system design. However, in the current system, it is difficult, if not impossible, to offer it. The problem is determining whether the switchboard(s) has enough space for an isolator and whether the switch room has enough space for the power factor correction panel, among other things.

The APFCU can be put in either a low voltage (LV APFCU) or a high voltage (HV APFCU) system, or both. Low and high voltage technologies are offered for APFCU.

- Active system
- Passive system

A. Conventional Vs Active Power Factor Correction Systems:

In the conventional system the capacitor units are controlled by contactors. In the active system the capacitors are controlled by thyristors.

The active system is expensive as compared to the passive system but gives no extra advantage. The power factor is maintained at same level by both systems. Just because load is fluctuating doesn't mean active system being fast will correct it better than the passive system. Remember the power factor measurement is not instantaneous power factor but average over a billing period. Therefore, whether active or passive system is used the average power factor generated by the APFCU over the billing period is same.

B. Centralized vs Decentralized Power Factor Correction System:

The APFCU can be installed at:

One or few main switchboards (central system).

At each load or at each switchboard/distribution board (decentralized system) The centralized option is cheaper in terms of capital and maintenance cost. For most consumers centralized system is a better option than decentralized system and works fine.

1. Decentralized Power Factor Correction System:

The power factor correction capacitor fitted at each load is shown in Figure 7. The capacitor unit is placed ahead of the thermal overload relay so that the inrush current from the capacitor does not travel through the relay. As a result,

when the motor is turned on, the relay will not malfunction owing to capacitor inrush current. In this instance, never use a soft-starter to start the motor since the inrush current drawn by the capacitors will harm it. [20]

The decentralized scheme suits low voltage agriculture customers where major load is few pump motors.

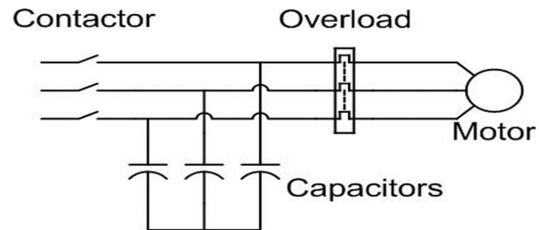

Figure 7. Decentralized power factor correction system for pump motor load.

2. *Centralized Power Factor Correction System:* In the centralized system the APFCU is installed at low or high voltage main switchboard(s) or motor control centre(s).

VIII. LOW VOLTAGE OR HIGH VOLTAGE APFCU

The choice between low or high voltage APFCU depends up on the type of loads in the electrical system.

- If all the loads are low voltage, then APFCU is provided in the low voltage system.
- If all the loads are high voltage, then APFCU is provided in the high voltage system.
- If the loads are low voltage and high voltage then APFCU are provided in the low voltage and high voltage system.

A. Location of APFCU:

If the electrical system has only main switchboard, then provide APFCU at that switchboard. If the electrical system has more than one switchboard, each connected to its own transformer, then provide APFCU at each of these main switchboards.

The APFCU can either be part of the switchboard or on its own near the switchboard (inside a similar free standing vertical panel). The decision depends up on the space availability. If the APFCU is inside the switchboard then the length of the switchboard will increase. If the space available in the switch room is not enough then it won't be possible to install such a switchboard. In which case the APFCU is installed separate from the switchboard.

1. *APFCU inside and part of the main switchboard:* This is the preferred and most common option if enough space is available in the switchroom.



Figure 8. Automatic power factor correction unit inside the main switchboard.

2. *APFCU separate from main switchboard:* This option is used when the sufficient space is not available in the switchroom. In the figure below there is not enough space (due to building column inside the switchroom) in the switch room to install the APFCU inside the main switchboard and therefore it is separate from the main switchboard.[21]



Figure 9. Automatic power factor correction unit separate from main switchboard.

IX. CONCLUSIONS

Low and high voltage capacitors for power factor correction are available. Capacitors for power factor correction systems are three-phase units with deltas attached inside to provide the highest output for the same capacitance. To improve reliability and availability, the power factor correction system's capacitors are internally fused. Although capacitors do not produce harmonics, they can be harmed by harmonics in the electrical system to which they are attached. However, having a series reactor solves the problem fully. A central power factor correction system is more cost effective than a dispersed system. A high-voltage power factor correction system is more expensive than a low-voltage solution.

REFERENCES

- [1] G. Sravanthi, P. Kovida Ramya, K. Varalaxmi, T. Dheeraj Kumar, "Penalty Reduction in Industrial Power Consumption by Employing APFC Unit," Vol. 9, pp. 135-138, April-2020.
- [2] M. Chandana1 , T. Chandrakala, T. Karthaveerya, C. L. Saisaran, P. Prathyusha, N. Pavankumar, "Automatic Power Factor Compensation for Industrial Power Use to Minimize Penalty," Volume 10, pp. 26777- 26779, 2020.
- [3] Miss Aaiman S Shaikh, Prof. Laxman S Patil, "Automatic Power Factor Correction," Volume: 06, pp.474-477, Sep 2019.
- [4] Bilal Naji Alhasnawi, Dr Basil H.Jasim, "Automated Power Factor Correction for Smart Home," Volume 14, pp. 31-40, January 2018.
- [5] Chaudhary Deepak , Gurjar Dharmesh, Misra Sameer, Nishad Rakesh, Jigar A. Tailor, "Minimizing Penalty in Industries by Engaging Automatic Power Factor Correction Unit," Vol. 7, pp. 3029- 3036, March 2018.
- [6] Saurabh Kumar Sharma, Gaurav Kumar Sharma, Abhijeet Sharma, "A REVIEW PAPER ON AUTOMATIC POWER FACTOR CORRECTION," Volume 6, pp. 120-1123, April 2018.
- [7] rpitha Raju1 , Jithendra K S , Mithun K S , Sanjay K R, "Minimizing Penalty in Industrial Power Consumption By Engaging APFC Unit," Vol. 7, pp. 91-94, April 2018.
- [8] Maryam Nabihah Zaidi, Adlan Ali, "Power Factor Improvement Using Automatic Power Factor Compensation (APFC) Device for Medical Industries in Malaysia," pp. 1-6, 2018.
- [9] Praveen V.A, Sumaya Fathima, Sumalata I. A, Badiger K. D, Kandagal S. S, "Automatic Power Factor Correction Using Capacitor Banks and 8051 microcontroller," Volume-3, pp. 163-167, June 2015.
- [10] P. William, G. R. Lanke, V. N. R. Inukollu, P. Singh, A. Shrivastava and R. Kumar, "Framework for Design and Implementation of Chat Support System using Natural Language Processing," 2023 4th International Conference on Intelligent Engineering and Management (ICIEM), London, United Kingdom, 2023, pp. 1-7, doi: 10.1109/ICIEM59379.2023.10166939.
- [11] Mall, S., Srivastava, A., Mazumdar, B.D., Bangare, S.L., Deepak, A., Implementation of machine learning techniques for disease diagnosis, *Materials Today: Proceedings*, 2022, 51, pp. 2198–2201.
- [12] Bhargava, A., Bansal, A., Goyal, V., Machine learning-based automatic detection of novel coronavirus (COVID-19) disease, *Multimedia Tools and Applications* 2022.
- [13] William, P., Shrivastava, A., Shunmuga Karpagam, N., Mohanaprakash, T.A., Tongkachok, K., Kumar, K. (2023). Crime Analysis Using Computer Vision Approach with Machine Learning. In: Marriwala, N., Tripathi, C., Jain, S., Kumar, D. (eds) *Mobile Radio Communications and 5G Networks. Lecture Notes in Networks and Systems*, vol 588. Springer, Singapore. https://doi.org/10.1007/978-981-19-7982-8_25
- [14] Agrawal, S.C., Jalal, A.S., Distortion-free image dehazing by superpixels and ensemble neural network, *Visual Computer*, 2022.
- [15] Gupta, A., Mazumdar, B.D., Mishra, M., ...Srivastava, S., Deepak, A., Role of cloud computing in management and education, *Materials Today: Proceedings*, 2023, 80, pp. 3726–3729
- [16] P. William, G. R. Lanke, D. Bordoloi, A. Shrivastava, A. P. Srivastava and S. V. Deshmukh, "Assessment of Human Activity Recognition based on Impact of Feature Extraction Prediction Accuracy," 2023 4th International Conference on Intelligent Engineering and Management (ICIEM), London, United Kingdom, 2023, pp. 1-6, doi: 10.1109/ICIEM59379.2023.10166247.
- [17] Deepak, A., Ganesan, V., and Shankar, P. Non Destructive Evaluation of Graphene based strain sensor using Raman Analysis and Raman Mapping, *Journal of Polymer Engineering*, accepted September 17, (2015).
- [18] Deepak, A., Shukla, P., Ganesan, V., and Shankar, P. Scrutinizing the Properties of Functionalized Graphene Based Polymer Nanocomposites for Electronic Devices, *Materials Today Proceeding*. (Elsevier)(2015).
- [19] Renganathan, B., Rao, S.K., Kamath, M.S., Deepak, A., Ganesan, A.R., Sensing performance optimization by refining the temperature and humidity of clad engraved optical fiber sensor in glucose solution concentration, *Measurement: Journal of the International Measurement Confederation*, 2023, 207,
- [20] William, P., Shrivastava, A., Chauhan, P.S., Raja, M., Ojha, S.B., Kumar, K. (2023). Natural Language Processing Implementation for Sentiment Analysis on Tweets. In: Marriwala, N., Tripathi, C., Jain, S., Kumar, D. (eds) *Mobile Radio Communications and 5G Networks. Lecture Notes in Networks and Systems*, vol 588. Springer, Singapore. https://doi.org/10.1007/978-981-19-7982-8_26
- [21] Sree Lakshmi, P., Deepak, A., Muthuvel, S.K., Amarnatha Sarma, C Design and Analysis of Stepped Impedance Feed Elliptical Patch/Antenna Smart Innovation, Systems and Technologies, 2023, 334, pp. 63.