

# Biometric Fingerprint Identification for Bank Locker Security System

Vishal Goyal  
Electronics & Communication  
Engineering  
GLA University  
Mathura, India  
vishal.goyal@gla.ac.in

Hemant Singh Pokhariya  
Department of Computer Science &  
Engineering  
Graphic Era University  
Dehradun, India  
hemantsinghpokhariya@geu.ac.in

Shubhi Gupta  
Department of Computer Sciences  
Amity University  
Greater Noida, Uttar Pradesh, India  
sgupta1@gn.amity.edu

N Shalini  
Dept of Computer Sc. & Engg.  
Institute of Aeronautical Engineering  
Hyderabad, India  
nima.shalini26@gmail.com

Ajay Rana  
Amity University  
Greater Noida, Uttar Pradesh, India  
ajay\_rana@amity.edu

Rajeev Ranjan  
Lloyd Institute of Management and  
Technology  
Greater Noida  
research.9871@gmail.com

**Abstract-** The implementation of the security system for all devices is through passive communication technology. People from different origins and different regions need a security system for their regions for all their platforms. The convincing type of security system is that it makes sure that it works under proper guidance and natural care of the system. The leverage for the security devices is to make them work under proper conditions and the defined process. The One-time password-based technology is also used for the security system and other surveillance of the system. The process of communication and the surveillance system is wholly monitored by the one-time password-based security theme. The major surveillance is done by the process of superior convenience through the successive surveillance of the devices. The metropolitan areas which are under surveillance will be having the same banking systems through the adhesive nature of the locking system for security purposes and other amenities. The user who accesses the locker will be given a username and password for his access and then they have imprinted their fingerprint for extra care and security. People with extra care and security will be endowed with one-time password access through their registered mobile. The mechanized introduction to the locking system will be enhanced through the proposed system. Thus it will help making the system to work on its way to maintain security and safety of the devices which has been endowed and developed through it.

**Keywords:** *Fingerprint Sensor, Banking security, Communication system, Locking mechanism, Security, Banking devices.*

## I. INTRODUCTION

In this scenario, people of all ages require the best security-based devices and they will be not endangered by the size of communication. The bank locker system is one of the important and safest places to store valuable materials. The people who are concerned about their safety will be on the safer side of their possession helps to restore the devices that have been endowed with security. Bank lockers are one of the most secure devices that help to maintain the process of securing devices. The passive communication devices of the bank locker system is been deliberately used for the process of maintaining the naïve nature of the secured devices. The massive hit of the proposed system is that they are equipped with devices to deceive security. The security convenience is been measured by the posterior and anterior

major of the devices that have been equipped with the major commune devices. These identification technologies are equipped with security-based devices. The maintenance of these devices is readily invested in their major protocols. The communication of the devices is been maintained by the process of adsorbing maintained of the devices. The passive networking-based technique is been adhered to through the consequences of security-based surveillance.

The massive hit of the proposed system is been devised to measure the capacity of the surveillance. The measured devices are devised with the enthal values of the locking system. The mechanized machines are termed to measure the process of the security process to control the neural time of the network. The measured devices are maintained to maintain the process of security through measured time. The authentication process of making the linear devices is to ensure the positive possession of the secured devices.

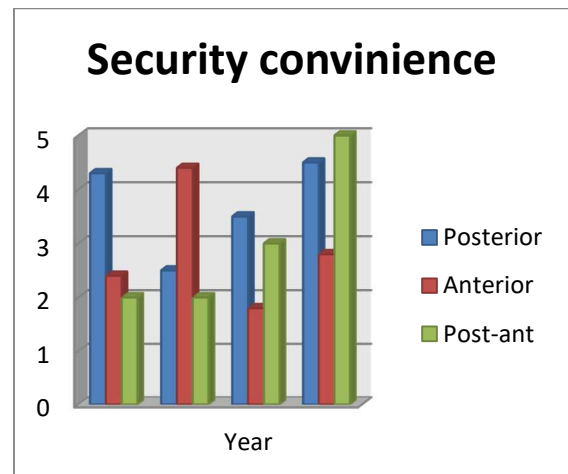

Figure: 1 Security Convenience

## II. LITERATURE REVIEW

The pervasive nature of communication is done under the smart locking system. Passive communication between the smart locking devices is been used to measure the security measures of the devices [1]. The naïve nature of the smart locking system is been adapted by the process of the smart device through the measuring devices [2]. The support nature of the smart verifies and the locking system is been

deployed by the pervasive demand [3]. The major deployment of the system is been activated to enhance the security of the devices. GSM-based technology is used for smart and small-scale communication between the devices and people will be able to communicate passively [5]. The process of communication between the smart locking systems through the GSM-based technology is been out-dated due to its back-end process [6]. The main proposed system concentrated on the internet of things which helps in maintaining the security and safety of the system [7]. The other existing systems like the biometric system for the smart locking devices are mainly used for the security and safety of the system with biometrics is good but as for the senses the system is getting deteriorated due to the less active convenience and safety [8-10]. Thus the most active proposed system is been upgraded with the biometric systems which have soft security appliances and measures to make sure of great security of the system [11-12]. Most of the banking securities systems have only fingerprints for the safety systems but we need more reliable software to control the safety [13]. The system needs extra care and security for their system to propagate the entire new brands. RFID-based scanners are also used to provide security in most of the needed devices [14]. The post posterior system of the existing system will be able to do the referential pages of the offset devices and it ensures to help the manufactured defect of the system. The postage of the devices and their security is been upgraded and balanced through phases of majestic appearances of the chances. The vendor of the system is been enabled through the majestic changes in the diluted version of the software [15]. The chances of getting an up gradation of the devices and enhancing the feature of the devices is been enabled to control and maintained the system.

### III. PROPOSED WORK

The execution of the security system for all of the contraptions is through idle correspondence development. People from different starts and different areas need the security structure for their regions for their entire establishment. The convincing sort concerning security structures is that it makes highlights it works under genuine course and typical thought of the system is shown in Figure: 2 as the bank locking security mechanism. The inescapable idea of correspondence is finished under the brilliant locking framework. [16] Detached correspondence between the brilliant locking gadgets is been utilized to gauge the safety efforts of the gadgets. The innocent idea of the shrewd locking framework is been adjusted by the course of the brilliant gadget through the estimating gadgets. The helpful idea of the brilliant checks and the locking framework is been sent by the unavoidable interest. A significant arrangement of the framework is been initiated to improve the security of the gadgets. GSM-based innovation is utilized for savvy and limited scope correspondence between the gadgets and individuals will want to impart latently. The course of correspondence

between the shrewd locking frameworks through the GSM-based innovation is been out-dated because of its back-end

process.[17] The fundamental proposed framework focused on the web of things which helps in keeping up with the security and well-being of the framework. The other existing frameworks like the biometric framework for the savvy locking gadgets are predominantly utilized for the security and well-being of the framework with biometrics is great yet concerning the faculties the framework is getting decayed because of the less dynamic comfort and security. Accordingly, the most dynamic proposed framework is been updated with the biometric frameworks which have delicate security apparatuses and measures to ensure the extraordinary security of the framework. The vast majority of the financial protection frameworks have just fingerprints for the security frameworks however we want more solid programming to control the security. The framework needs additional consideration and security for its framework to spread the whole new brands. RFID-based scanners are additionally used to give security to the majority of the required gadgets. The post-back arrangement of the current framework will want to do the referential pages of the offset gadgets and it guarantees to help the produced deformity of the framework.

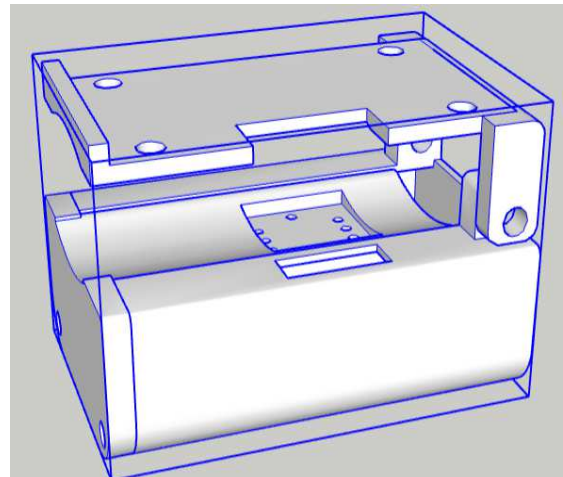

Figure 2. Bank lockers

The postage of the gadgets and their security is been redesigned and adjusted through periods of glorious appearances of the possibilities. [18] The seller of the framework is been empowered through the glorious changes in the weakened form of the product. The possibilities of getting an up degree of the gadgets and improving the elements of the gadgets is been empowered to control and kept up with the framework. The impact of the security contraptions is to make them work under proper conditions and the portrayed cycle. The One-time secret expression-based development is similarly used for the security system and various perceptions of the structure. The course of correspondence and the perception structure is altogether checked by the one-time mystery express-based security point. The huge perception is done by the course of transcendent solace through the dynamic observation of the devices. [19]The metropolitan locales which are under the perception will have comparable monetary structures through the concrete thought of the

locking system for security purposes and various comforts are shown using the chart in the figure: 3 of time variance.

The client who gets to the capacity will be given a client name and mystery word for his special entry and subsequently, they have engraved their finger impression for extra thought and security. People with extra thought and security will be provided with one-time mystery word access through their selected flexible. The robotized preface to the locking structure will be overhauled through the proposed system as shown in the neural time linear chart of figure: 4 with the time-lapse period and the neutral time linear system and the enthralling time of the system. The bank storage framework is one of the significant and most secure spots to store important materials. Individuals who are worried about their well-being and security on their assist with re-establishing the gadgets that have been enriched with security.

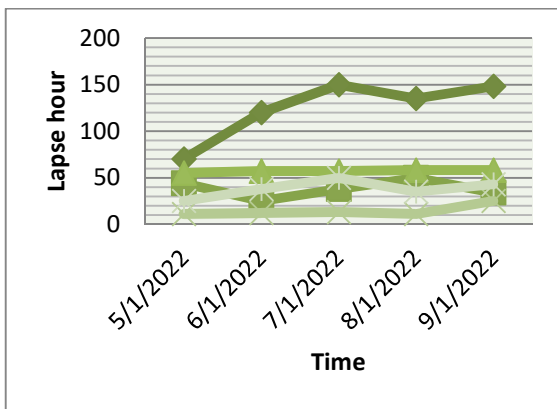

Figure 3. Time variant Chart

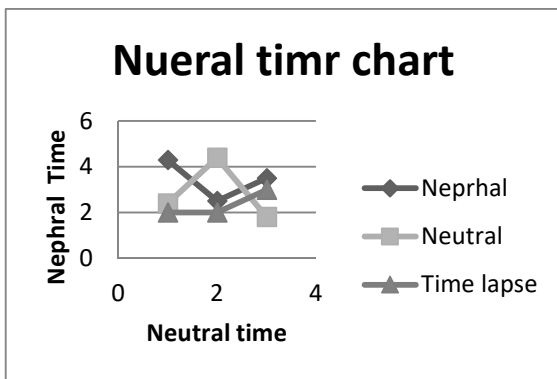

Figure 4. Neural Time chart

IV. RESULT AND DISCUSSION

The bank storage spaces are quite possibly the most solid gadget that assists to keep up with the course of gotten gadgets. The aloof specialized gadgets of the bank storage framework is been intentionally utilized for the method involved with keeping up with the credulous idea of the got gadgets. The monstrous hit of the proposed framework is that they are outfitted with gadgets to bamboozle security. The security comfort is been estimated by the back and foremost major of the gadgets that have been outfitted with the significant cooperative gadgets. The security comfort is been estimated by the back and foremost major of the

gadgets that have been furnished with the significant community gadgets.

V. CONCLUSION

These ID innovations are furnished with security-based gadgets. The upkeep of these gadgets is promptly put resources into their significant conventions. The correspondence of the gadgets is been kept up with by the most common way of adsorbing kept up with of the gadgets.

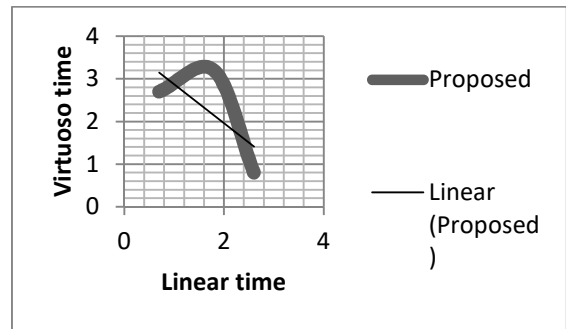

Figure 5. linear time variance

The uninvolved systems administration-based method is been stuck through the results of the security-based observation. The huge hit of the proposed framework is been contrived to gauge the limit of the observation.[20] The deliberate gadgets are contrived with the captivating upsides of the locking framework. The automated machines are named to gauge the course of the safety cycle to control the brain season of the organization. The deliberate gadgets are kept up with to keep up with the course of safety through estimated time. The validation interaction of making the direct gadgets is to guarantee the positive ownership of the got gadgets.

REFERENCES

- [1] Jadhav, Subhash H., and S. S. Agrawal. "Smart Bank Locker Security System Using Biometric Fingerprint and GSM Technology." *International Journal of Science and Research (IJSR)*, ISSN (Online) (2022): 2319-7064.
- [2] Pooja, K. M., et al. "Fingerprint-based bank locker security system." *Int. J. Eng. Res. Technol.(IJERT) NCESC 6.13 (2022)*: 1-5.
- [3] Patil, Rachana Yogesh, and Manjiri Ranjanikar. "Biometric authentication based smart bank locker security system." *Second International Conference on Image Processing and Capsule Networks: ICIPCN 2021 2*. Springer International Publishing, 2022.
- [4] Shankar, A. Aditya, et al. "Fingerprint-based door locking system." *International Journal Of Engineering And Computer Science 4.3 (2022)*: 10810-10814.
- [5] Dewangan, Rekha, Vishnu Kumar Mishra, and Megha Mishra. "A review on secured bank locker system using fingerprint, image and RFID technique." *Int. Res. J. Eng. Technol.(IRJET) 7.07 (2020)*: 4786-4789.
- [6] Gayathri, M., P. Selvakumari, and R. Brindha. "Fingerprint and GSM-based security system." *International journal of engineering sciences & research technology 1.3 (2021)*: 4024-7.
- [7] Verma, Amit. "A multi-layer bank security system." *2013 International Conference on Green Computing, Communication, and Conservation of Energy (ICGCE)*. IEEE, 2021.
- [8] Bedi, Harpreet. "Fingerprint Image Identification System: An Asset for Security of Bank Lockers." *Digital Forensics and Internet of Things: Impact and Challenges (2022)*: 227-235.

- [9] Chikara, Arvasu, Pallavi Choudekar, and Divya Asija. "Smart Bank Locker Using Fingerprint Scanning and Image Processing." 2020 6th International Conference on Advanced Computing and Communication Systems (ICACCS). IEEE, 2020.
- [10] Nasrin, Atar, et al. "Fingerprint Based Security System for Banks." *International Research Journal of Engineering and Technology (IRJET)-Volume 3* (2022).
- [11] Bedi, Harpreet. "Design of a Secure Fingerprint Bank Locker for Bank Security." *Futuristic Sustainable Energy and Technology*. CRC Press, 2022. 27-32.
- [12] Tejesvi, S. V., et al. "Intellectual bank locker security system." *Int. J. Eng. Res. Appl* 6.2: 31-34.
- [13] Balla, Prashanth Balraj, and K. T. Jadhao. "IoT-based facial recognition security system." 2018 international conference on smart city and emerging technology (ICSCET). IEEE, 2020.
- [14] Thomas, Akash, Kezia Mariam Varghese, and Sheba Elizabeth Kurian3Er Ashly John. "FINGERPRINT BASED BANK LOCKER SECURITY SYSTEM." (2021).
- [15] Naveen, P., et al. "Bank Locker Security System Using QR Code." *Annals of the Romanian Society for Cell Biology* (2021): 4218-4227.
- [16] Renganathan, B., Rao, S.K., Kamath, M.S., Deepak, A., Ganesan, A.R., Sensing performance optimization by refining the temperature and humidity of clad engraved optical fiber sensor in glucose solution concentration, *Measurement: Journal of the International Measurement Confederation*, 2023, 207.
- [17] William, P., Shrivastava, A., Chauhan, P.S., Raja, M., Ojha, S.B., Kumar, K. (2023). Natural Language Processing Implementation for Sentiment Analysis on Tweets. In: Marriwala, N., Tripathi, C., Jain, S., Kumar, D. (eds) *Mobile Radio Communications and 5G Networks. Lecture Notes in Networks and Systems*, vol 588. Springer, Singapore. [https://doi.org/10.1007/978-981-19-7982-8\\_26](https://doi.org/10.1007/978-981-19-7982-8_26)
- [18] Sree Lakshmi, P., Deepak, A., Muthuvel, S.K., Amarnatha Sarma, C Design and Analysis of Stepped Impedance Feed Elliptical Patch Antenna *Smart Innovation, Systems and Technologies*, 2023, 334, pp. 63.
- [19] Gupta, A., Mazumdar, B.D., Mishra, M., ...Srivastava, S., Deepak, A., Role of cloud computing in management and education, *Materials Today: Proceedings*, 2023, 80, pp. 3726–3729
- [20] P. William, G. R. Lanke, D. Bordoloi, A. Shrivastava, A. P. Srivastavaa and S. V. Deshmukh, "Assessment of Human Activity Recognition based on Impact of Feature Extraction Prediction Accuracy," 2023 4th International Conference on Intelligent Engineering and Management (ICIEM), London, United Kingdom, 2023, pp. 1-6, doi: 10.1109/ICIEM59379.2023.10166247.
- [21] Deepak, A., Ganesan, V., and Shankar, P., Non-Destructive Evaluation of Graphene based strain sensor using Raman Analysis and Raman Mapping, *Journal of Polymer Engineering*, accepted September 17, (2015).
- [22] Sachdeva, A., Tomar, V.K., Characterization of Stable 12T SRAM with Improved Critical Charge, *Journal of Circuits, Systems and Computers*, 2022.