

Internet of Things Based Reduction of Electricity Theft in Urban Areas

Hemant Gupta

Department of Electrical Engineering,
GLA University
Mathura, India
hemant.gupta@gla.ac.in

Resham Taluja

Department of Mechanical Engineering
Graphic Era University
Dehradun, India
reshamtaluja_2048.me@geu.ac.in

Sanchita Shaw

Lloyd Institute of Engineering and
Technology
Greater Noida, India
research.9871@gmail.com

S. Lakshmana Chari

Department of Computer Sc. & Engg.
Institute of Aeronautical Engineering
Hyderabad, India
lakshmansiddi@gmail.com

A. Deepak

Saveetha Institute of Medical and
Technical Sciences
Chennai, India
deepakarun@saveetha.com

Ajay Rana

Amity University
Greater Noida, Uttar Pradesh, India
ajay_rana@amity.edu

Abstract - In most areas, theft is a common disaster that always threatens people from all areas and makes them deeply hurt. As such nowadays theft is advanced to its next level such as electricity theft in urban areas. People use the motors to thrive energy without any charges and any surge in the electricity will be affected. The portion of theft is been getting more lavishly increasing and makes the admin get a surge from the theft. The basic needs of the people are also been looted in these forms and make the other user wait for their turn to use the leftover power. The importance of theft reduction is so important in urban areas. Most of the theft is been activated in industrial areas. The theft is been detected through the internet of things using the smart meters that have been installed in all the units to control and measure the power consumption. Unlike another usual meter, the Internet of things based smart meters helps the admin to detect the usage of electricity without any probability of change in the mutual ranges. The most important factor for all the meters that is been a dedicated smart meter is been installed to control the factors all the time. The smart meter works accordingly through artificial intelligent-based smart sensors. The perfect time to lapse the meter is to enrich the device by its process of communication between the devices and the sensor units. The fact of making it possible for commercial uses only as such most of the commercial places are involved in this drift based thrive of theft.

Keywords - Internet of things, Cloud storage, Data dependency, Data coherency, Latency, Artificial intelligence.

I. INTRODUCTION

The important of all the system and major fuel to the system is electricity. People are nothing without electricity and electricity made everyone's life into a most alluring one. The importance of electricity is that one cannot live without it as such the surge of electricity is also growing in demand and people are using it lavishly and making them work according to their usage and their control of time. Electricity needs is been in high demand due to most of the commercial industries blooming to control the pace of the population. As such the population is growing big and big people require electricity and they are demanding the proper electricity for their daily needs. Even the bigger commercial institutions are rendering many needs for electricity.

As the electricity needs are growing bigger and bigger nowadays as shown in the figure: 1. the Same kind of process of theft in the electric fields is also growing bigger and makes some sense to the people who require more electricity. The need for electricity and the amount of consumption and the charge per unit has increased by then and now so people started stealing electricity from the nearby fields and even in their places too. This made electricity theft increase from time to time. Electricity theft has become a violent one in the era and the drastic changes in the effervescences of the timely manner. The condition that changes the feature of extraction is to ensure the wide nation of making the sense of dynamic theft.

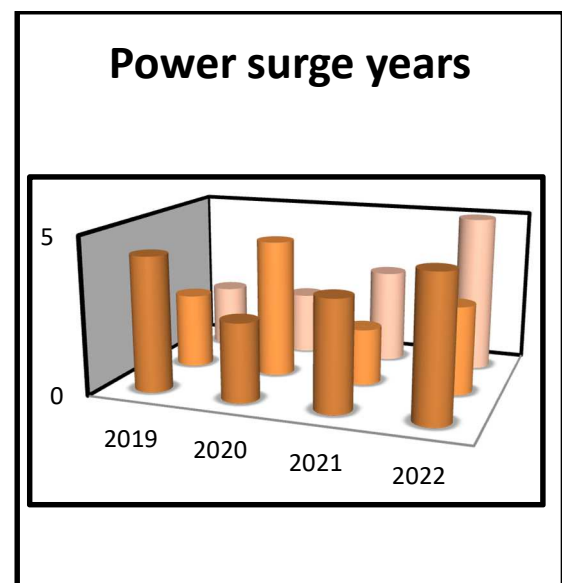

Figure 1. Power surge in different years.

The power surge in the system is been adopted to measure the electricity usage in the particular field and the concern of their system. The momentary process of communication between the system to reduce the theft of electricity is been dynamically changed through the time era. The position and control mechanism to maintain the prosecution of the central mechanism to control the process of changing the system to ensure the development of the electricity board. The propagation of controlling the recessive mechanism to maintain the progressive change in the dimensional criteria

of odd senses is to control the process of the electricity management protocol. Electricity theft is been processed and controlled through the passive mechanism of the system. The underlying theft is been maintained to measure the process of sensational relief in the area.

II. LITERATURE REVIEW

The importance of electricity theft is been deployed in most of the current situations and production units are destined in the process. The measurement of making sense of electrification to reduce theft is been deployed through the smart grids but these smart grids are electrified and cost more in their production unit and the construction of these grids [1]. The procedural sense of the progression in the processor is been detective through the masterpiece and they sense through the processor and make them control the measures through the possessive progress [2]. The importance of communication between the devices is been developed and eloped through the internet of things and the destined system is been developed through the controlled mechanism of the sensors. The sensors are devised with the internet of things and their scheduled time is devices of the arena. The major thing is to enhance the propagation of the denial to control theft [3]. The progressive nature of the devices is been devised to measure the internet width and the treasure of the range of the wideband system.

The control mechanism is been deployed to measure the proctoring effects in the electricity management unit is been deployed by the devised sensors [4]. The main strategy to control the pressure of the system is to control the process of control measures to maintain the electricity consumption data sets. The data sets that have been pre-processed control the process of measuring the data sets to reduce the latency and data dependency in the area [5]. Effervesces of the system to control the pre-planned data consumption is to maintain the process of feature management and extraction [6]. The classification of the devices to maintain the process of evaluation technique to the loss factor in the embedded system of controlled devices [7]. The main importance of the sensors is deprecated and maintained under the low balance control mechanism. The process of maintaining the batch process is to control the emission of excess electricity to the circuits of the system which is been deemed by the unit of electricity board [8]. The process of communicating the devices through the system through electric systems is a kind needed in the current era [9]. The passive outcome of the reliable system is been evaluated and consumed by the treasury of the electric brands of the system and their relevance is been added to the conclusive nature of the provident areas [10]. The process of controlling the electricity dividend scales is measured under the neutral way of their propagation [11].

The conclusive nature of the mature electric-based devices is been adapted to make the system emulsify nature. The maximized nature of the system will demand the level of the peer nature of the system's nature [12]. The bright communication between the devices and their

communication is brightened by the piece of the electric devices that tends to cultivate a civilization [13]. The major drawback of the existing systems is that they tend to propose a near-cultivable situation for the arena and its surroundings [14]. The passive income between the peer natures of the proposed system is to cultivate and civilize the arena with the proper electricity background and the nature to withstand the position in the area [15].

III. PROPOSED WORK

Electricity management and control are important factors in all fields. People tend to make sure that their devices are working properly through the major science of the flow of electrons in the devices. The factor is to make sure that the theft of electricity is reduced using the timer-based meters with the internet of things module to reduce the usage of the electricity. The electric devices that have been melded through the internet of things is been deduced to receive compliments in the wages of electricity usage and their prospective. The major difference between the normal meter and the proposed meter is to measure the difference in the range of changes in the electricity. The controlled nature of the meter is to ensure them to control meter ranges within spices and then changes them to the controlled perspective as shown in figure: 2.

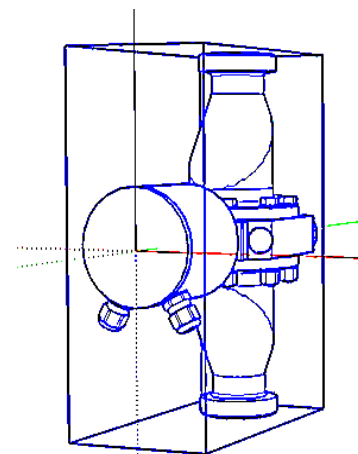

Figure 2. Proposed Meter

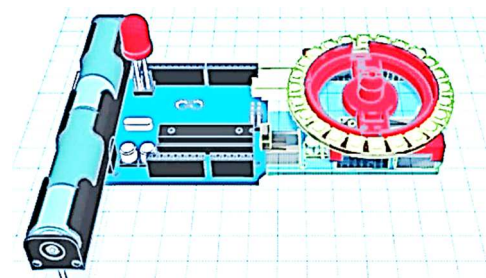

Figure 3. Proposed Circuitry

This made power robbery increment occasionally. The power burglary has turned into a brutal one in the period and the radical changes in the fizzes of the opportune way.[16-17] The condition that changes the element of

extraction is to guarantee the wide country of comprehending dynamic robbery. The power flood in the framework is been taken on to gauge the power use in the specific field and the worry of their framework. The quick interaction of correspondence between the framework to diminish the robbery of power is been progressively different through the period. The engendering of controlling the passive system to keep up with the ever-evolving change in the layered rules of odd faculties is to control the course of power the board convention is shown in the figure: 5.

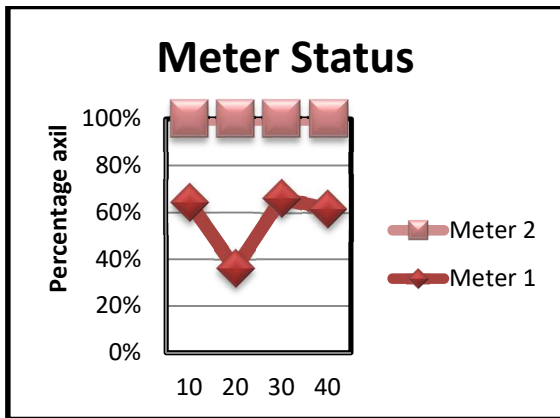

Figure 4. Characteristic chart of the proposed meter

IV. RESULT AND DISCUSSION

The significance of power is that one can't live with it as such the flood of power is likewise filling popular and individuals are utilizing it richly and making them work as per their utilization and their control of time [18]. The power needs is been in popularity due to the vast majority of business ventures blossoming to control the speed of the populace. As such the populace is developing an enormous number of individuals who need power and they are requesting the appropriate power for their day-to-day needs. Indeed, even the greater business foundations are delivering many requirements for power. As the power needs are developing increasingly big these days is displayed in the figure: 7. same sort of course of burglary in the power fields is likewise becoming greater and sounds good to individuals who are needing greater power.[19] The need for power and how much the utilization and the charge per unit have been expanded by then, at that point, and presently so individuals began taking power from the close by fields and, surprisingly, in their places as well.

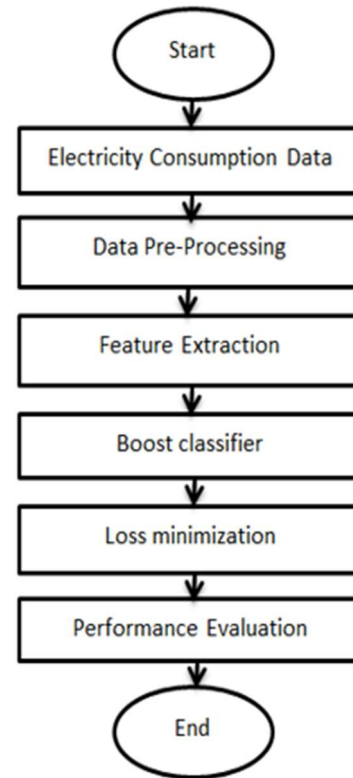

Figure 5. Flow chart of the proposed system

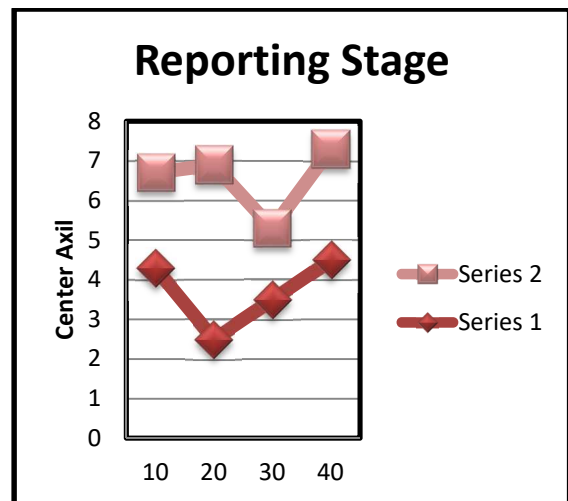

Figure 6. Characteristic chart of the reporting stage.

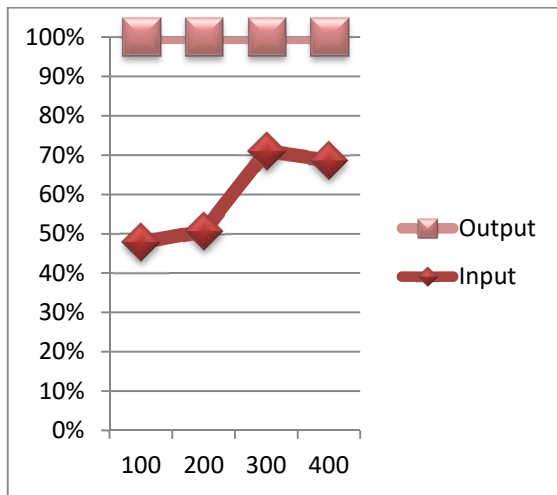

Figure 7 Proposed system Results

V. CONCLUSION

The burglary is been recognized through the web of things utilizing the shrewd meters that have been introduced in every one of the units to control and gauge the power utilization. Not at all like other regular meters had the Web of things based brilliant meters helped the administrator to identify the utilization of power with next to no likelihood of progress in the shared reaches. The main element for every one of the meters is been a committed brilliant meter is been introduced to control the variables constantly. The brilliant meter works likewise through the counterfeit shrewd-based savvy sensors. [20] The ideal opportunity to pass the meter is to enhance the gadget by its course of correspondence between the gadgets and the sensor units. The reality of making it feasible for the business utilizes just as such the greater part of the business places are engaged with these float-based flourish of the burglary.

REFERENCES

- [1] Banga, Alisha, Ravinder Ahuja, and S. C. Sharma. "Accurate detection of electricity theft using classification algorithms and Internet of Things in smart grid." *Arabian Journal for Science and Engineering* 47.8 (2022): 9583-9599.
- [2] Darth, Oscar Famous, et al. "Design of Internet of Things based Electricity Theft Detection using Raspberry PI." *International Journal of Engineering Research & Technology* 10.2 (2021): 506-511.
- [3] Ogu, R. E., and G. A. Chukwudebe. "Development of a cost-effective electricity theft detection and prevention system based on IoT technology." *2017 IEEE 3rd international conference on electro-technology for national development (NIGERCON)*. IEEE, 2022.
- [4] Mohanty, Sumit, M. Mohamed Iqbal, and Parvathy Thampi. "Controlling and Monitoring of Power Theft using Internet of Things." *2021 International Conference on Design Innovations for 3Cs Compute Communicate Control (ICDI3C)*. IEEE, 2021.
- [5] Ibrahim, Mohamed I., et al. "Electricity-Theft Detection for Change-and-Transmit Advanced Metering Infrastructure." *IEEE Internet of Things Journal* 9.24 (2022): 25565-25580.
- [6] Manikandan, A., and S. Pradeep. "IoT Based Electricity Theft Detection." *International Journal of Control Theory and Applications* 10.12 (2022): 211-215.
- [7] Nalinaksh, Kumar, Lokesh Pathak, and Vinay Rishiwal. "An Internet of Things solution for real-time identification of electricity theft and power outages caused by a fault in distribution systems (converting existing electrical infrastructure of third world countries to Smart Grids)." *2018 3rd International Conference On Internet of Things: Smart Innovation and Usages (IoT-SIU)*. IEEE, 2022.
- [8] Ibrahim, Mohamed I., et al. "Efficient privacy-preserving electricity theft detection with dynamic billing and load monitoring for AMI networks." *IEEE Internet of Things Journal* 8.2 (2022): 1243-1258.
- [9] Xia, Xiaofang, et al. "A Control-Chart-Based Detector for Small-Amount Electricity Theft (SET) Attack in Smart Grids." *IEEE Internet of Things Journal* 9.9 (2022): 6745-6762.
- [10] Tehrani, Soroush Omidvar, Mohammad Hossein Yaghmaee Moghaddam, and Mohsen Asadi. "Decision tree based electricity theft detection in smart grid." *2020 4th International conference on smart city, internet of things and applications (SCIOT)*. IEEE, 2021.
- [11] Nabil, Mahmoud, et al. "Deep recurrent electricity theft detection in AMI networks with evolutionary hyper-parameter tuning." *2019 International Conference on Internet of Things (iThings) and IEEE Green Computing and Communications (GreenCom) and IEEE Cyber, Physical and Social Computing (CPSC), and IEEE Smart Data (SmartData)*. IEEE, 2022.
- [12] Kaushik, Jatin, et al. "Minimizing Electricity Theft by the Internet of Things."
- [13] Deepak, A., Shukla, P., Ganesan, V., and Shankar, P. "Scrutinizing the Properties of Functionalized Graphene Based Polymer Nanocomposites for Electronic Devices, Materials Today Proceeding. (Elsevier)(2015).
- [14] Renganathan, B., Rao, S.K., Kamath, M.S., Deepak, A., Ganesan, A.R., "Sensing performance optimization by refining the temperature and humidity of clad engraved optical fiber sensor in glucose solution concentration, Measurement: Journal of the International Measurement Confederation, 2023, 207,
- [15] William, P., Shrivastava, A., Chauhan, P.S., Raja, M., Ojha, S.B., Kumar, K. (2023). Natural Language Processing Implementation for Sentiment Analysis on Tweets. In: Marriwala, N., Tripathi, C., Jain, S., Kumar, D. (eds) Mobile Radio Communications and 5G Networks. Lecture Notes in Networks and Systems, vol 588. Springer, Singapore. https://doi.org/10.1007/978-981-19-7982-8_26
- [16] Sree Lakshmi, P., Deepak, A., Muthuvel, S.K., Amarnatha Sarma, C "Design and Analysis of Stepped Impedance Feed Elliptical Patch Antenna Smart Innovation, Systems and Technologies, 2023, 334, pp. 63
- [17] Wisetsri, Worakamol, et al. "Electricity Theft Detection and Localization in Smart Grids for Industry 4.0." *INTELLIGENT AUTOMATION AND SOFT COMPUTING* 33.3 (2022): 1473-1483.
- [18] Sannidhan, M. S., Jason Elroy Martis, and Abhir Bhandary. "A cost-effective approach for detecting electricity theft using the raspberry pi board." *2017 International Conference on Current Trends in Computer, Electrical, Electronics and Communication (CTCEEC)*. IEEE, 2022.
- [19] Khattak, Hasan Ali, et al. "Dynamic pricing in the industrial internet of things: Blockchain application for energy management in smart cities." *Journal of Information Security and Applications* 55 (2021): 102615.
- [20] Agrawal, S.C., Jalal, A.S., "Distortion-free image dehazing by superpixels and ensemble neural network, Visual Computer, 2022.